

NATIONAL ADVISORY COMMITTEE FOR AERONAUTICS

WARTIME REPORT

ORIGINALLY ISSUED
May 1945 as
Advance Restricted Report L5D23

AN ELECTROMAGNETIC-ANALOGY METHOD OF SOLVING
LIFTING-SURFACE-THEORY PROBLEMS

By Robert S. Swanson and Stewart M. Crandall

Langley Memorial Aeronautical Laboratory
Langley Field, Va.

NACA

WASHINGTON

NACA WARTIME REPORTS are reprints of papers originally issued to provide rapid distribution of advance research results to an authorized group requiring them for the war effort. They were previously held under a security status but are now unclassified. Some of these reports were not technically edited. All have been reproduced without change in order to expedite general distribution.

Digitized by the Internet Archive
in 2011 with funding from

University of Florida, George A. Smathers Libraries with support from LYRASIS and the Sloan Foundation

712 05 1
361315X

NACA ARR No. L5D23

NATIONAL ADVISORY COMMITTEE FOR AERONAUTICS

ADVANCE RESTRICTED REPORT

AN ELECTROMAGNETIC-ANALOGY METHOD OF SOLVING
LIFTING-SURFACE-THEORY PROBLEMS

By Robert S. Swanson and Stewart M. Crandall

SUMMARY

A method is suggested for making lifting-surface calculations by means of magnetic measurements of an electromagnetic-analogy model. The method is based on the perfect analogy between the strength of the magnetic field around a conductor and the strength of the induced-velocity field around a vortex. Electric conductors are arranged to represent the vortex sheet. The magnetic-field strength is determined by measuring, with an electronic voltmeter, the voltage induced in a small search coil by the alternating current in the wires representing the vortex sheet.

Solutions of nonlinear lifting-surface problems may be obtained by placing the conductors representing the trailing vortices along the fluid lines (Helmholtz condition). A potential-flow solution for the distortion and rolling up of the trailing-vortex sheet may be obtained. By use of the Prandtl-Glauert rule, the lifting-surface theory may be adapted to include first-order compressibility effects.

A comparison was made of the downwash determined by means of a preliminary electromagnetic-analogy model with the downwash obtained by calculation for an elliptic wing having an aspect ratio of 3. The accuracy of the magnetic measurements compared satisfactorily with the accuracy of the downwash calculations.

INTRODUCTION

There are many important aerodynamic problems for which solutions by lifting-line theory are inadequate. These problems can be solved much more satisfactorily by

a lifting-surface theory; that is, a theory in which the lift is assumed to be distributed over a surface instead of along a line. The calculations necessary to determine solutions by lifting-surface theory, however, are rather laborious even for the simplified case in which the variation in incremental pressures with the effective camber or the angle of attack of the surface is linear. A more exact nonlinear solution is very nearly impossible to calculate except for a few special cases. A few of the aerodynamic problems for which solutions by lifting-surface theory are desired are: the plan-form corrections necessary for the prediction of finite-span hinge-moment characteristics from section data; the determination of spanwise and chordwise load distributions of wings with low aspect ratio, wings with sweep, wings in sideslip, wings in roll, and wings in turning flight; more exact solutions for the unsteady lift of finite wings; and an improved theory of the field of flow near propellers.

In reference 1 it was shown that the plan-form corrections determined from lifting-line theory are inadequate for hinge-moment predictions. The plan-form corrections determined by a linear lifting-surface theory (reference 2), however, were shown to be quite satisfactory for the prediction of hinge moments at small angles of attack. For wings at larger angles of attack, especially for wings with square tips, a nonlinear lifting-surface theory is required.

The electromagnetic-analogy method was developed in an attempt to make calculations by both linear and nonlinear lifting-surface theories practical. The time and expense required to build and test an electromagnetic-analogy model of a wing and wake were expected to be small compared with the cost of applying other methods available at present, even for the linear case. The electromagnetic-analogy method is based on the fact that the magnetic field around a wire carrying electric current is perfectly analogous to the velocity field around a vortex. It has also been shown (reference 3) that the lifting surface and wake may be represented by a vortex sheet and may therefore be replaced by conductors arranged in the configuration of the equivalent vortex sheet. Simple measurements of the magnetic-field strength then replace the difficult induced-velocity calculations.

For nonlinear solutions of lifting-surface problems, the trailing-vortex sheet represented by the wires is rolled up and distorted instead of lying in a plane as it

is usually assumed to do. In figure 1 is shown a simplified picture of a rectangular wing of low aspect ratio at a large angle of attack with a rolled-up and distorted trailing-vortex sheet. Of the various features of the distorted vortex sheet that contribute to the nonlinearity, the most important is the vertical spacing of the trailing vortices. The increase in vertical spacing as the angle of attack is increased results in a decrease in the vertical component of induced velocity at the surface, especially near the wing tips; thus the slope of the lift curve is increased as the angle of attack increases (see reference 4) and the slopes of hinge-moment curves are more negative (reference 1).

The present report describes the basic theory of the electromagnetic-analogy method and the general procedure by which various aerodynamic problems may be solved by this analogy. A few preliminary results for the linear case are presented for an elliptic wing having an aspect ratio of 3, as well as a comparison of the results obtained by the present method and the results calculated by the method of reference 2.

SYMBOLS

Γ	vortex strength
Γ_{\max}	maximum vortex strength
Δp	pressure difference across lifting surface
V	free-stream velocity
M	mach number, ratio of free-stream velocity to sonic velocity
ρ	fluid density
x	distance along free-stream direction from leading edge of wing
y	spanwise distance
z	vertical distance above plane of vortex sheet
H	magnetic-field strength

i	current in conductor
e	induced voltage
l	length of conductor or vortex
r	distance from element of conductor or vortex to point in question
v	induced velocity
w	vertical component of induced velocity (downwash)
u	horizontal component of induced velocity (free-stream direction)
K	constant
t	time
b	span
c	chord

Bar above symbol indicates a vector, as \bar{H} , \bar{l} , \bar{r} , and \bar{v} .

BASIC THEORY

Solution of Aerodynamic Problems by Available

Lifting-Surface Theories

The distribution of lift over a lifting surface cannot, in general, be expressed in any simple mathematical form such as can be obtained by lifting-line theory. This statement is especially true for nonlinear lifting-surface problems. Except for a few special plan forms (references 5 and 6), the method of determining the induced downwash for a given lift distribution also is too complex for expression in mathematical form. In order to obtain an exact, complete analytical solution, however, such expressions must be known.

The determination of the surface to sustain an arbitrary lift distribution may be accomplished by means of the electromagnetic-analogy method described herein or, for the linear case, by the semigraphical method of reference 2. The inverse problem, determining the lift distri-

bution over an arbitrary surface, may then be solved by a process of successive approximations. A reasonable distribution of vorticity is assumed or calculated from the simple lifting-line and thin-airfoil theories, and the induced velocities corresponding to that vortex distribution are determined by making an electromagnetic-analogy model of the vortex sheet and measuring the magnetic-field strength. If the induced velocities do not satisfy the boundary conditions - that is, the shape of the lifting surface - the vortex sheet is suitably altered and the process repeated until the boundary conditions are satisfied. For the non-linear problem, not only must the induced velocities satisfy the boundary conditions of the wing shape but also the trailing vortices must satisfy the Helmholtz condition, namely, that the vortices must trail along fluid lines. (See reference 7.) In practice, satisfying these simple conditions may require a considerable amount of work unless the first approximation is fairly accurate. In order to obtain a somewhat more general solution, for the linear case at least, the surfaces required to support several different lift distributions may be determined so that the shape for a particular lift distribution may be estimated by a process of interpolation or superposition.

There are, however, several problems for which a complete potential-flow solution of the inverse problem is not necessary. For example, in order to include the main effects of viscosity, the estimation of the hinge-moment parameter for finite-span wings should be made by applying theoretical aspect-ratio corrections to experimental section hinge-moment parameters. For such problems the additional aspect-ratio corrections may be determined simply and accurately from the surface required to support a given lift distribution (reference 1) as found by lifting-surface theory.

The results of the electromagnetic-analogy solution of the lifting-surface theory may be corrected for first-order compressibility effects by a simple application of the Prandtl-Glauert rule (reference 8). The method consists of determining the incompressible-flow characteristics of an equivalent wing the chords of which are increased by the factor $\frac{1}{\sqrt{1 - M^2}}$. It is therefore necessary only to build an electromagnetic-analogy model of a wing of this slightly lower aspect ratio (lower by the factor $\frac{1}{\sqrt{1 - M^2}}$) or to test models of several aspect ratios and interpolate. The

pressures (or vorticity) acting upon this incompressible equivalent of lower aspect ratio, however, must be increased by the factor $\frac{1}{\sqrt{1 - M^2}}$. In order to find the lift, these increased pressures are referred to the original wing and integrated.

Vortex Sheet

Inasmuch as the equivalence of a lifting wing and wake to a vortex sheet may be considered to be well established (reference 3), only the important characteristics of the equivalent vortex sheet and the relations between the lifting wing and the vortex sheet will be given.

The part of the vortex sheet representing the lifting wing consists of a sheet of bound vortices. The strength of the vortices is directly associated with the lift distribution of the wing. The product of the air density, the free-stream velocity, the vortex length perpendicular to the free-stream velocity, and the vortex strength of each elementary vortex equals the lift contribution by that elementary vortex (Kutta-Joukowski law). If the lift distribution of the wing is known or assumed, therefore, the equivalent vortex distribution may be easily obtained. A continuous lift distribution (as measured by pressure distribution Δp) may be integrated to give a continuous vortex distribution. The integration formula (reference 2) for obtaining the vortex distribution is

$$\Gamma = \int_0^x \frac{\Delta p}{\rho V} dx \quad (1)$$

where ρV is the product of the density and the free-stream velocity and the integration is made in the free-stream direction. Equation (1) gives the chordwise Γ -function at each section. The values of Γ at the trailing edge of the wing at each section also give the spanwise vortex distribution of the wake. The bound vortices may be assumed to lie along a mean surface, half-way between the upper and lower surfaces of the wing.

The part of the vortex sheet representing the wake consists of the so-called trailing vortices. As the name implies, these vortices originate at the trailing edge of the wing and merely trail behind the wing. These vortices are free to move and thus lie along the local stream lines, or fluid lines. This simple kinematic condition, the Helmholtz condition (reference 7), determines the configuration of the trailing-vortex sheet.

The trailing vortices for lightly loaded wings usually lie very near a plane; that is, these vortices travel almost straight back from their origin at the trailing edge of the wing. For highly loaded wings, however, the trailing-vortex sheet is known to be considerably distorted, rolled up, and inclined with respect to the free-stream direction. (See fig. 1.) The characteristics of the air flow behind wings are described in more detail in references 9 and 10.

Electromagnetic Analogy

The perfect analogy that exists between the strength of the magnetic field around conductors and the strength of the induced-velocity field around columnar (finite-diameter) vortices is well known. In fact, the phenomena of the induced velocities around vortices are usually explained in aerodynamic textbooks by the analogy with electromagnetic phenomena. Both phenomena are potential flows.

The vector form of the differential equation for the magnetic-field strength $d\vec{H}$ at any point caused by the current i flowing in an infinitesimal length $d\vec{l}$ of wire is (from p. 242 of reference 11)

$$d\vec{H} = i \frac{d\vec{l} \times \vec{r}}{|\vec{r}|^3} \quad (2)$$

where \vec{r} is the vector from the current element to the point in question. This equation is usually called the Biot-Savart law in aerodynamic textbooks.

The same form of equation (2) but with different constants applies to the induced velocity $d\vec{v}$ at any point caused by an infinitesimal length $d\vec{l}$ of a vortex of strength Γ (reference 9); that is,

$$d\vec{v} = \frac{\Gamma}{4\pi} \frac{d\vec{l} \times \vec{r}}{|\vec{r}|^3} \quad (3)$$

The units in which the various quantities in equations (2) and (3) are usually measured are widely different. In equation (2), for example, H is usually given in gauss, i in abamperes, and l and r in centimeters. In equation (3), v is usually in feet per second, Γ in feet squared per second, and l and r in feet.

Small search coils are used to measure the strength of the magnetic field. These search coils must be calibrated in magnetic fields of known strength - for example, in a Helmholtz coil (fig. 2). If the vortex equation (3) and the usual vortex units are used to compute the induced velocity in the Helmholtz coil (p. 269, reference 11) - that is, are used as the calibrating unit - and if the ammeter measuring the current in the Helmholtz coil is considered to read vortex strength, conversions of electromagnetic to aerodynamic units will not be necessary. All conversions and constants become merely a part of the overall calibration constant of the search coils.

CONSTRUCTION OF ELECTROMAGNETIC-ANALOGY MODELS

Approximate Representation of Continuous Vortex Sheet

The replacement of a continuous vortex distribution by a finite number of conductors must, of course, involve some approximation. Two procedures for constructing models have been tried. For the preliminary electromagnetic-analogy model, a set of 50 circular electric wires carrying the same current (connected in series) representing 50 columnar vortices of equal strength were distributed over the wing and wake. (See fig. 3.) The arrangement of the wires was determined as follows: Fifty contour lines of Γ were calculated from equation (1). (See reference 2.) Each wire was placed halfway between two adjacent Γ -contour lines and thus represented $\Delta\Gamma/\Gamma_{\max} = 0.02$. In order to illustrate the degree of the approximation involved, the continuous chordwise Γ -function at the plane of symmetry and the stepwise distribution of wires used to represent the continuous distribution are given in figure 4.

The possibility of errors resulting from the use of an incremental distribution is, however, more serious than simply the possibility of not obtaining a good representation of the distribution of vorticity in the continuous wake. The induced velocity resulting from an incremental vortex pattern may vary greatly about the mean value that would be obtained by the continuous sheet, because the magnitude of the induced velocity varies inversely with distance from the vortex core and becomes higher than the mean value on one side of each stepwise vortex increment and lower than the mean value on the other side. The

effect is illustrated in figure 5. It is thus necessary to use as many wires as practicable to approach as nearly as possible a continuous sheet and to measure the induced velocities at a great number of points so that the mean value of the induced velocity may be obtained more easily and more accurately from faired curves.

The preliminary model, constructed of 50 wires, gave satisfactory results and it is believed that 50 is about the optimum number of wires. Construction difficulties are too great if more wires are used, and the accuracy is not great enough if fewer wires are used. Another, more complex method of construction was adopted for a few models but the results obtained were not much more accurate than those obtained with the simpler wire construction method. The other construction method was to use thin aluminum strips (resulting in "flat wires") rather than circular copper wires (fig. 6), the reason for this type of construction being that a more nearly continuous distribution of vorticity and a corresponding smoother induced-velocity field could be obtained. The effect of eddy currents in the aluminum strips proved to be more important than was originally expected, however, and the induced magnetic field was only slightly smoother than with circular wires and was not so regular; thus difficulties in fairing the measured induced magnetic field proved to be about the same for both types of model.

Correction for Finite Thickness of Wires

Calculations by the lifting-surface theory are usually made for points in the plane of the vortex sheet. Because the wires representing the vortices are of finite thickness, the magnetic-field strength must be measured at several vertical heights and extrapolated to zero, that is, to the center of the wires. Except near the wing tips and the leading edge of the wing, this extrapolation is usually linear and can thus be made quite accurately. The fact that measurements are made above the wires simplifies the fairing problem, because the variation in the magnitude of the vertical component of induced velocity about the mean value (fig. 5) decreases with increase in vertical height.

Correction for Finite Length of Trailing-Vortex Sheet

For the steady-state condition of a finite-span lifting surface, the trailing-vortex sheet extends from the trailing edge of the wing infinitely far downstream. It is necessary to determine corrections for the finite length of trailing-vortex sheet of the electromagnetic-analogy models. The wires representing the incremental vortices were connected in series; the closing loops were about 0.7 span behind the wing for one model and about 2 spans behind the wing for another model. (See fig. 3.) Because the correction for the approximation of the infinite length of the trailing-vortex sheet is fairly small - about a 5-percent correction for a 0.7-span wake and less than 1-percent correction for a 1.5- to 2.0-span wake - it appears that wakes need not be longer than 1.5 spans. More downwash is contributed by the closing loops than by the missing trailing vortices. The correction is simply the difference between the downwash contribution of the closing loops and the contribution of the missing part of the trailing-vortex sheet. The corrections are small and can usually be estimated by assuming that the span loading is a simple rectangular loading or the sum of two rectangular loadings.

The corrections may also be determined from measurements of the induced field at a distance behind the closing wires equal to the length of wake represented. That is, if a measurement is made at the corresponding spanwise point 1 wake length behind the model, the effect will be the same as if a measurement were made on the wing of the downwash due to a mirror image of the model reflected from the closing loops. Such an image would cancel the effect of the closing loops and would double the length of the wake. The remaining error is relatively small.

SUGGESTED METHOD OF MEASURING MAGNETIC-FIELD STRENGTH

Several methods of measuring the magnetic-field strength were investigated. The fundamental principle of the method selected as being the simplest and as requiring the least special equipment and the least development work is given herein. This method consists in passing alternating currents through the wires representing the vortex sheet and measuring the magnetic-field strength by means of the

voltage induced in a small search coil. A discussion of other possible methods of measuring the magnetic-field strength is given in the appendix.

Basic Principles

According to the principles of electromagnetic induction (reference 11), the electromotive force induced in a fixed circuit (the search coil, in this case) by changing the magnetic flux through the coil is equal to the time rate of change of flux linkages with the coil. If an alternating current is passed through the wires representing the lifting wing and the wake, the magnetic-field strength will also be alternating at the same frequency and with the same wave shape. This fact may be seen from equation (2), because the instantaneous value of $\frac{d\Phi}{dt}$ is proportional to the instantaneous value of i .

A simple method of determining the magnetic-field strength, therefore, is to measure with an electronic voltmeter the voltage induced in a small search coil (fig. 7) when alternating current is passed through the wires representing the vortices (fig. 3). The search coil is directional; that is, this coil measures only the component of magnetic-field intensity along the axis of the coil.

Practical Problems

Upper-frequency limit.- Because the voltage induced in the search coil is proportional to the rate of change of flux, it would seem desirable to use a very high-frequency current so that the voltage induced in the search coil would be very large and thus somewhat easier to measure. The maximum frequency that may be used, however, is about 300 cycles, because the capacitance between the closely spaced wires in the model representing the vortex sheet becomes important above this frequency. If greater frequencies are used, capacitive reactance becomes sufficiently low to have perceptible effect. When the capacitive reactance between wires becomes small, the current is not the same in all wires even though they are connected in series. The maximum allowable frequency was determined from measurements of the capacitive reactance of the electromagnetic-analogy model used for the preliminary tests, to be described in the section "Preliminary Tests with Electromagnetic-Analogy Model." The capacitive reactance, and thus the leakage current of this model, became measurable above about 300 cycles.

Several other models tested have had about the same or a higher limiting frequency; therefore, a 300-cycle limit is believed to be conservative.

Wave shape.- The fact that the frequency is limited to about 300 cycles also requires that the wave shape of the current in the vortex sheet be very nearly sinusoidal; that is, any departure from a simple sine wave means that higher harmonic frequencies are also present. Usually the most nearly sinusoidal wave shape is obtained by putting enough condensers in series with the model to balance the inductance of the model; in this way a pure resistance load is put on the generator.

The easiest way to determine the wave shape is to look at the voltage output of the search coil by means of an oscilloscope. This wave shape is not that of the current in the wires but depends on the rate of change of current i with time t - that is, the induced voltage e is equal to $K \frac{di}{dt}$. The amplitude of the third harmonic as seen on the oscilloscope is, then, three times the amplitude of the actual third harmonic of the current. In other words, the wave shape of the voltage output of the search coil looks much more irregular than the wave shape of the current in the wires actually is. If the filters that are added to the circuit make the voltage output of the search coil appear satisfactory, no further test is necessary.

Practically all alternators have wave shapes that are not sinusoidal and that change with load. The wave form of the current in the Helmholtz coil, used to calibrate the search coil, must be identical with that of the current in the electromagnetic-analogy model. Probably the easiest way to make these wave forms identical is to connect the Helmholtz coil and the electromagnetic-analogy model in series. The Helmholtz coil and the electromagnetic-analogy model should be placed as far apart as possible and should be oriented in such a way that downwash measurements on the analogy model are unaffected by the field of the Helmholtz coil and that the Helmholtz field is unaltered by the analogy-model field while the search coil is being calibrated. It would also be advantageous to effect an arrangement such that the search-coil calibration could be checked frequently. A fairly satisfactory arrangement was employed for the preliminary tests. (See fig. 8.) The leads from the search coil were long enough to go to either the Helmholtz coil or the analogy model.

Search coils.- The optimum size of the search coil depends upon two factors. First, the search coil must be small enough to make "point" measurements possible. If the coil is too large and the magnetic-field strength varies nonlinearly with position, the effective center of the coil may be too far from the geometric center. If the coil dimensions are kept small relative to the wing, little error due to this cause will result. The size of the search coil therefore depends upon the size of the electromagnetic-analogy model. The second consideration is that, for accurate voltage measurements, the voltage output of the search coil should be at least 0.0001 volt and a minimum value of 0.001 volt is preferable.

Several sizes of coil were tried with the preliminary model, and it is felt that the maximum-size search coil that gives measurements fairly close to point measurements is one with a diameter about 1 percent of the wing semi-span and a height about 0.5 percent of the wing semispan. In order to get the desired search-coil voltage output, the model semispan must be at least 3 to 4 feet and the search coil should have about 1000 turns and be wound with about No. 43 wire (0.0022-in. diam.). If a larger model is used, larger wire may be used to wind the coil, although wire as small as 0.001 inch was wound satisfactorily for the coil used for the preliminary tests. It is probably desirable to have a number of search coils (fig. 7) of various sizes, however, to meet any special conditions. Smaller coils are desirable near the leading edge and the tips of the wing and in other places where the flux field varies rapidly.

The search coil must be wound rather carefully so that all loops are as nearly perpendicular as possible to the axis of the coil in order to maintain the directional properties of the coil. The coil must then be carefully mounted on the survey apparatus. A test for the correct mounting (or alignment) of the coil is to read the voltage output of the small coil when mounted with its axis vertical at a position on the electromagnetic-analogy model where the horizontal component of the magnetic field is stronger than the vertical component. Regardless of how the search coil is turned about its vertical axis, the voltage output should be the same if the search coil is kept at the same place on the model.

The leads from the search coil to the electronic voltmeter must be twisted so that no large loops are present.

Otherwise, the voltage measured by the electronic voltmeter will not only be the voltage induced in the search coil but will also consist of the voltage induced in these leads. The errors resulting from pickup in the leads may be made negligible by tightly twisting the leads, by making the number of turns in the search coil large so that the lead pickup gives a small percentage error, and by bringing the leads in perpendicular to the vortex sheet so that the leads will be in the region of low magnetic-field strength.

Extraneous fields.- One of the most important problems in measuring the magnetic-field strength is to filter out all extraneous fields. It is desirable to make the tests in a wooden building fairly far from electrical disturbances such as electric motors and computing machines. Reasonably satisfactory results may be obtained in spite of these disturbances, if necessary, by the use of an electrical filter in the circuit of the search coil and electronic voltmeter. Such a filter suppresses any voltage of frequencies other than the one passing through the vortex sheet. Because the filter may act as a search coil itself, it must be located some distance from the model.

Measuring equipment.- No current should be drawn in measuring search-coil voltage, which is of the order of only 1 millivolt. Commercial electronic voltmeters combine the high sensitivity and high resistance demanded. Small amounts of power-supply ripple usually exist in these voltmeters. This power-supply ripple interferes with measurements made at integral multiples of the line frequency, and care should be taken to avoid use of these frequencies in testing.

PRELIMINARY TESTS WITH ELECTROMAGNETIC-ANALOGY MODEL

In order to check the accuracy of the electromagnetic-analogy method of solving lifting-surface problems, a vortex pattern for which the induced velocities had already been calculated by the method of reference 2 was investigated. Calculations were made of the vertical component of the velocities induced by a plane vortex sheet representing the lift distribution estimated from the two-dimensional theories for an elliptic wing having an aspect ratio of 3.

Equipment

A small model of the plane vortex sheet was constructed of 50 wires representing 50 incremental vortices. This model (fig. 3) represents about the smallest model (wing span of 3.3 ft) that will yield satisfactory results. A small search coil (fig. 7(a)) of 1000 turns was used to measure the magnetic-field strength. A Helmholtz coil (fig. 2) was used to calibrate the search coil. The power supply was a 500-cycle alternator driven by a direct-current motor, the speed of which was controlled so that the frequency output was held at 270 cycles. The direct-current field of the alternator was adjusted to give a current output of 8 amperes. The wave shape was very nearly sinusoidal (third harmonic, less than 4 percent of the first harmonic).

Some trial tests were made in the workshop of the Langley Atmospheric Wind Tunnel Section. The results proved unsatisfactory, however, because of excessive electric and magnetic interference. The apparatus was then moved to a large wooden building, in which there was very little electric and magnetic interference. The setup is shown in figure 8. The small amount of 60-cycle electric interference that was still present was eliminated by using a 100-cycle high-pass filter in the electronic-voltmeter circuit.

Results

A complete survey was made of the induced-velocity field (both the horizontal and vertical components) at from 50 to 100 chordwise points at each of 15 spanwise locations on the model and at several vertical heights. Near the leading edge and the tips of the model, the effect of vertical height was very large and, at all locations, the effect was large enough to require surveys at several heights in order that the results could be extrapolated to zero vertical height.

The most important component of induced velocity computed by lifting-surface theory is the vertical component. The only reason for measuring the horizontal component is to check the arrangement of the wires representing the vortices. According to the assumptions of thin-airfoil theory, the horizontal component of induced velocity is proportional to the pressure distribution. Values of the

horizontal component u of the induced velocity measured at a relative vertical height of $\frac{z}{b/2} = 0.008$ are shown in figure 9 along with the theoretical velocity distribution that the wing was built to represent. The agreement is satisfactory and indicates that the model was constructed with sufficient accuracy.

Chordwise surveys of the measured value of the vertical component w of the induced velocity are presented in figure 10 for several spanwise locations and vertical heights. (Not all of the data are presented.) These and similar data were extrapolated to zero vertical height (fig. 11) and corrected for the finite length of the trailing-vortex sheet (correction, about one-half of 1 percent) and are summarized in figure 12. Included in figure 12 are the calculated values. The agreement between the two sets of results may be seen to be satisfactory. The time and labor involved in obtaining the solution were considerably less (approximately one-third the man-hours) by the analogy method than by calculation, after the proper experimental technique had been determined.

CONCLUDING REMARKS

A method for making lifting-surface calculations by means of magnetic measurements of an electromagnetic-analogy model has been developed. The method is based on the perfect analogy between the strength of the magnetic field around a conductor and the strength of the induced-velocity field around a vortex. Electric conductors are arranged to represent the vortex sheet. The magnetic-field strength is determined by measuring, with an electronic voltmeter, the voltage induced in a small search coil by the alternating current in the wires representing the vortex sheet.

A comparison was made of the downwash determined by means of a preliminary electromagnetic-analogy model with the downwash obtained by calculation for an elliptic wing having an aspect ratio of 3. The accuracy of the magnetic measurements compared satisfactorily with the accuracy of the downwash calculations.

Other applications of the method include solutions of nonlinear lifting-surface problems obtained by placing

the conductors representing the trailing vortices along the fluid lines (Helmholtz condition). A potential-flow solution for the distortion and rolling up of the trailing-vortex sheet may be obtained. By use of the Prandtl-Glauert rule, the lifting-surface theory may be adapted to include first-order compressibility effects.

Langley Memorial Aeronautical Laboratory
National Advisory Committee for Aeronautics
Langley Field, Va.

APPENDIX

ALTERNATE METHODS OF MEASURING MAGNETIC-FIELD STRENGTH

By R. A. Gardiner

Several methods could be used to make the measurements described in this report. The methods that were considered are:

Pickup Device	Measuring Instrument
1. With d-c. field on wing	
a. Search coil (flip coil or collapse of field)	Ballistic galvanometer
b. Rotating search coil	
With slip rings	A-c. electronic voltmeter
With commutator	D-c. amplifier and voltmeter
c. Saturated-core magnetometer	Suitable electronic equipment
d. Torsion-type magnetometer	Suitable optical equipment
2. With a-c. field on wing	
a. Saturated-core magnetometer	Suitable electronic equipment
b. Bismuth bridge	Wheatstone bridge
c. Search coil	A-c. electronic voltmeter

The considerations that led to the choice of the method used (method 2c in the foregoing list) were the simplicity, the sturdiness and availability of the equipment, the development work required, the probable success and accuracy, the magnitude of field strength required, the minimum possible size of the pickup device, and the freedom from interference of stray fields. The outstanding

advantages or disadvantages of the various methods may be summarized as follows:

Method 1a.- The use of a search coil and ballistic galvanometer is the established method of magnetic-field measurement. In order to secure the necessary sensitivity, however, a rather delicate galvanometer would have to be used and would probably require a special vibration-free support. The flip coil would require tare readings of the earth's magnetic field. With a stationary coil and collapsing field, the inductance of the wing would prevent the desired instantaneous collapse, the galvanometer would not be used in a true ballistic manner, and errors would result.

Method 1b.- A rotating search coil and associated equipment have been used to make magnetic measurements; however, the induced voltages to be measured are lower than those usually measured by this method. The necessary sliding contacts would probably introduce thermal electromotive forces and variable resistance and would be subject to corrosion. Precision machine work would be necessary to minimize difficulties from the motor and bearings.

Methods 1c and 2a.- It is known that a coil containing a high-permeability metal (Permalloy or Mumetal) will have a large induced voltage across its terminals as the core becomes magnetically saturated. This induced voltage is due to the great change in inductance that occurs at the saturation point. This principle has been used in the measurement of magnetic fields; the field to be measured is superimposed upon a field set up in the core and the change in voltage due to saturation is measured. Although this method can be made very sensitive, a large amount of electronic equipment is necessary and the presence of a ferromagnetic substance might cause distortion of the field.

Method 1d.- The use of torsion magnetometer is an accurate method of measuring the earth's field. A small magnet suspended by a suitable fiber is deflected by the earth's field. This deflection is measured and, from the known magnetic moment of this magnet, the earth's field may be determined. The measuring element is very sensitive and the time necessary to take one reading is rather long. In addition, such an instrument would probably be of delicate construction.

Method 2b.- Resistance change due to the presence of magnetic lines takes place in bismuth. Measurement of the resistance change by use of a bridge is a possible method of measuring the magnetic-field strength. At present a powerful magnetic field is necessary in order to make practical measurements. Considerations of the available power supply eliminated this method.

Method 2c.- The method finally selected - that using an a-c. voltmeter, an a-c. field, and a small search coil for the pickup device - appeared to be the means which would be least troublesome and which would use easily available and simple components. Details of this method are given in the report.

REFERENCES

1. Swanson, Robert S., and Gillis, Clarence L.: Limitations of Lifting-Line Theory for Estimation of Aileron Hinge-Moment Characteristics. NACA CB No. 3L02, 1943.
2. Cohen, Doris: A Method for Determining the Camber and Twist of a Surface to Support a Given Distribution of Lift. NACA TN No. 855, 1942.
3. von Kármán, Th., and Burgers, J. M.: General Aerodynamic Theory - Perfect Fluids. Vol. II of Aerodynamic Theory, div. E, W. P. Durand, ed., Julius Springer (Berlin), 1935.
4. Bolley, William: A Non-Linear Wing Theory and Its Application to Rectangular Wings of Small Aspect Ratio. Z.f.a.N.M., Bd. 19, Heft 1, Feb. 1939, pp. 21-35.
5. Kinner, W.: Die kreisförmige Tragfläche auf potentialtheoretischer Grundlage. Ing.-Archiv, Bd. VIII, Heft 1, Feb. 1937, pp. 47-80.
6. Krienes, Klaus: The Elliptic Wing Based on the Potential Theory. NACA TM No. 971, 1941.
7. Prandtl, L.: Applications of Modern Hydrodynamics to Aeronautics. NACA Rep. No. 116, 1921.
8. Goldstein, S., and Young, A. D.: The Linear Perturbation Theory of Compressible Flow, with Applications to Wind-Tunnel Interference. R. & M. No. 1909, British A.R.C., 1943.
9. Silverstein, Abe, Katzoff, S., and Bullivant, W. Kenneth: Downwash and Wake behind Plain and Flapped Airfoils. NACA Rep. No. 651, 1939.
10. Kaden, H.: Aufwicklung einer unstablen Unstetigkeitsfläche. Ing.-Archiv, Bd. II, Heft 2, May 1931, pp. 140-168.
11. Page, Leigh, and Adams, Norman Ilsley, Jr.: Principles of Electricity. D. Van Nostrand Co., Inc. (New York), 1931.

The first part of the document discusses the importance of maintaining accurate records of all transactions. It emphasizes that every entry should be supported by a valid receipt or invoice. This ensures transparency and allows for easy verification of the data.

In the second section, the author details the various methods used to collect and analyze the data. This includes both manual and automated processes. The goal is to ensure that the data is as accurate and reliable as possible.

The third part of the document focuses on the results of the analysis. It shows that there is a clear trend in the data, which is consistent with the initial hypothesis. This finding is significant as it provides strong evidence for the proposed model.

Finally, the document concludes with a summary of the findings and a list of recommendations for future research. It suggests that further studies should be conducted to explore the underlying causes of the observed trends.

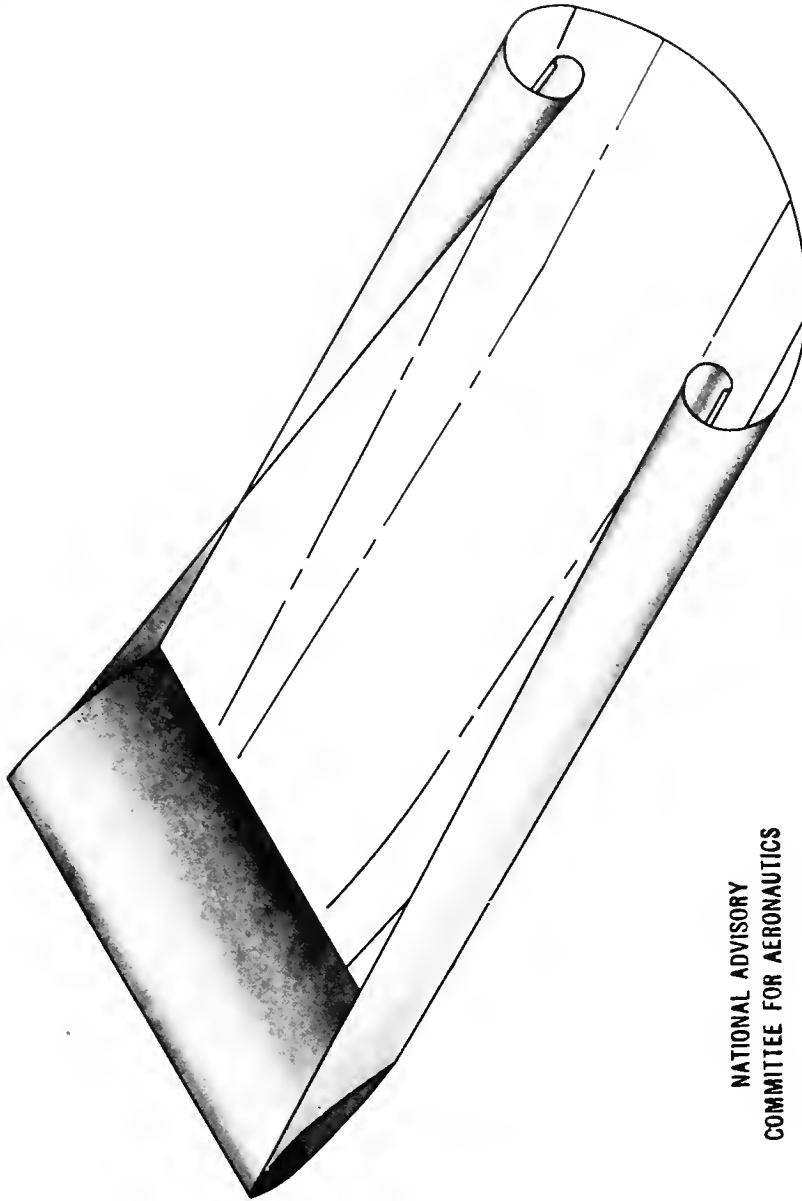

NATIONAL ADVISORY
COMMITTEE FOR AERONAUTICS

Figure 1. - Illustration of the rolling-up of the trailing-vortex sheet behind a rectangular wing of low aspect ratio.

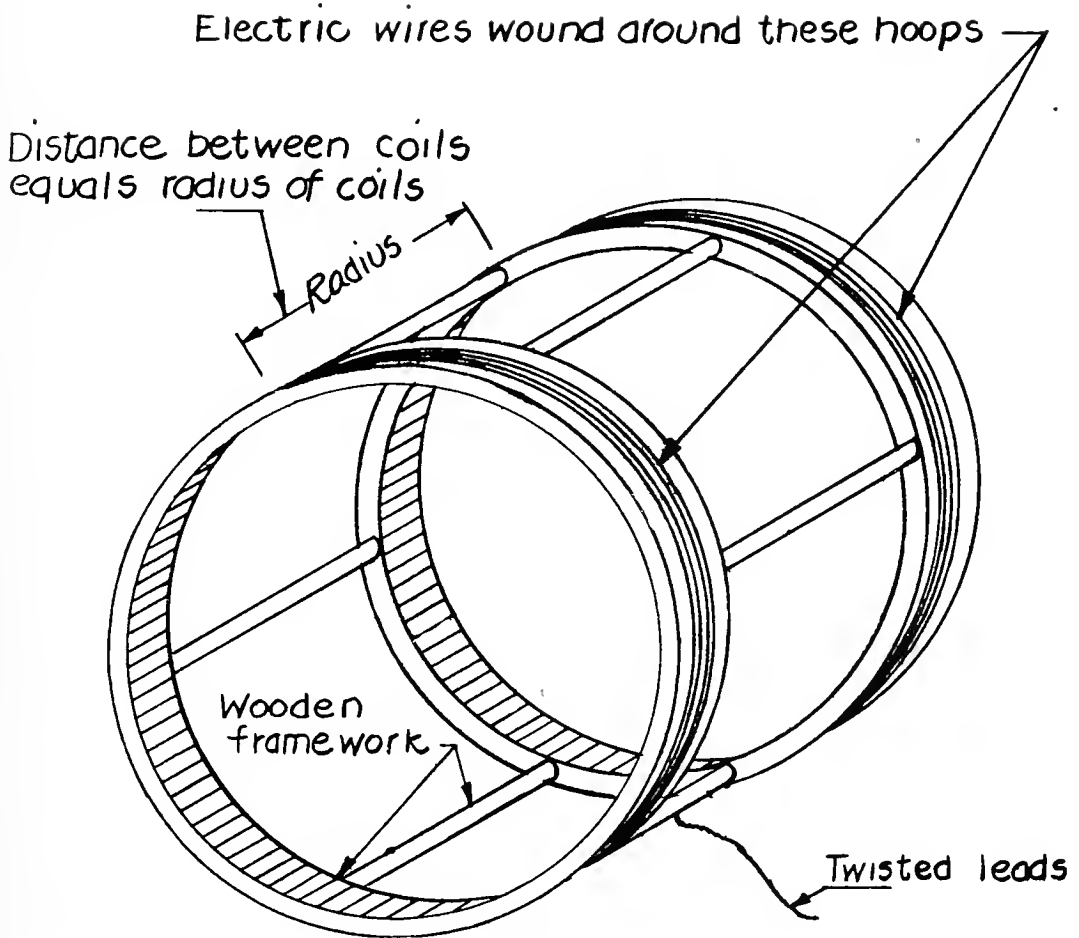

NATIONAL ADVISORY
COMMITTEE FOR AERONAUTICS

Figure 2.- A Helmholtz coil. The search coil to be calibrated is located in the geometric center of the Helmholtz coil.

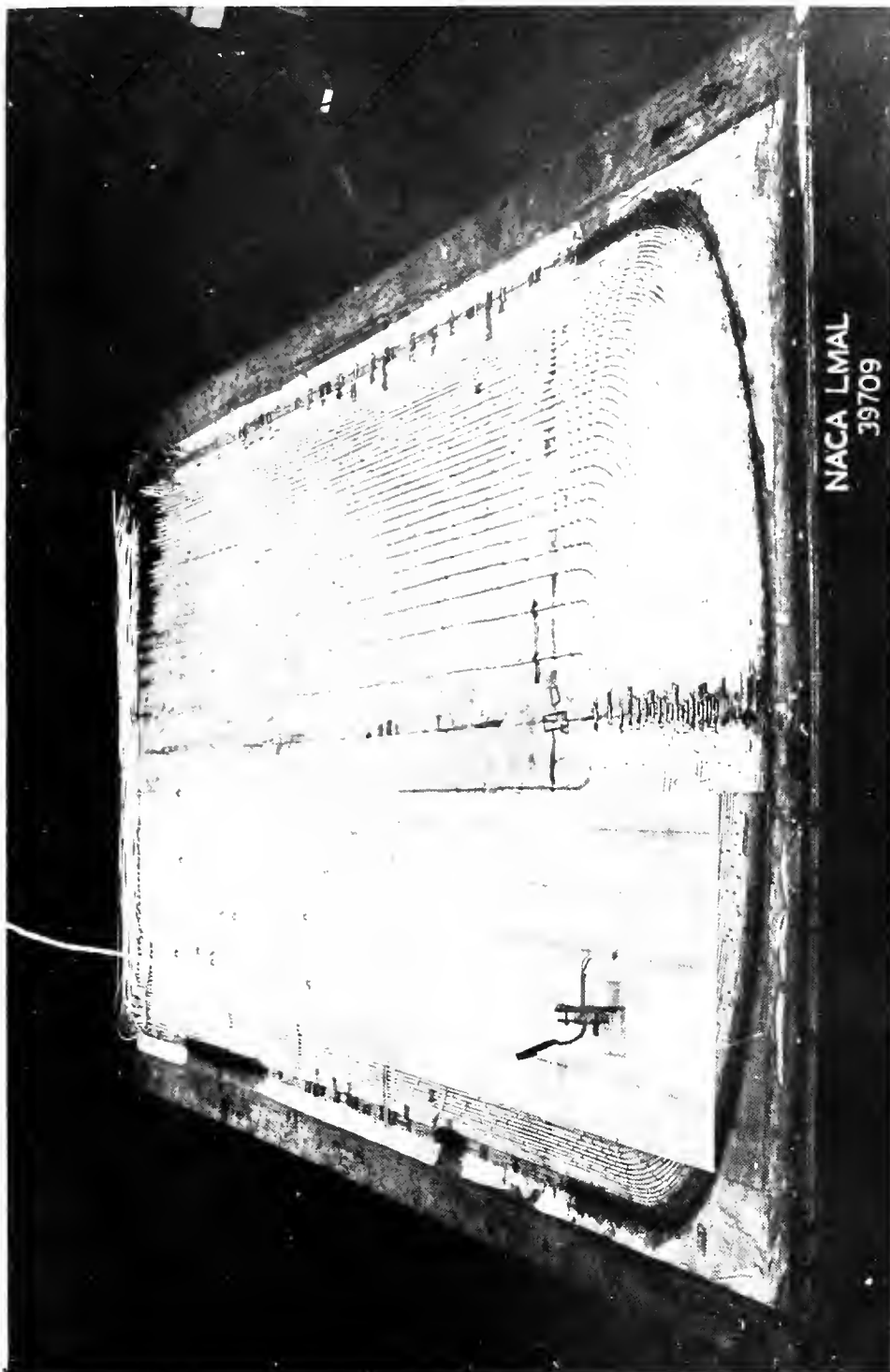

Figure 3.- Preliminary electromagnetic-analogy model of elliptic wing of aspect ratio 3 with flat-plate-type loading. (Wake represented for distance equal to about twice wing span.)

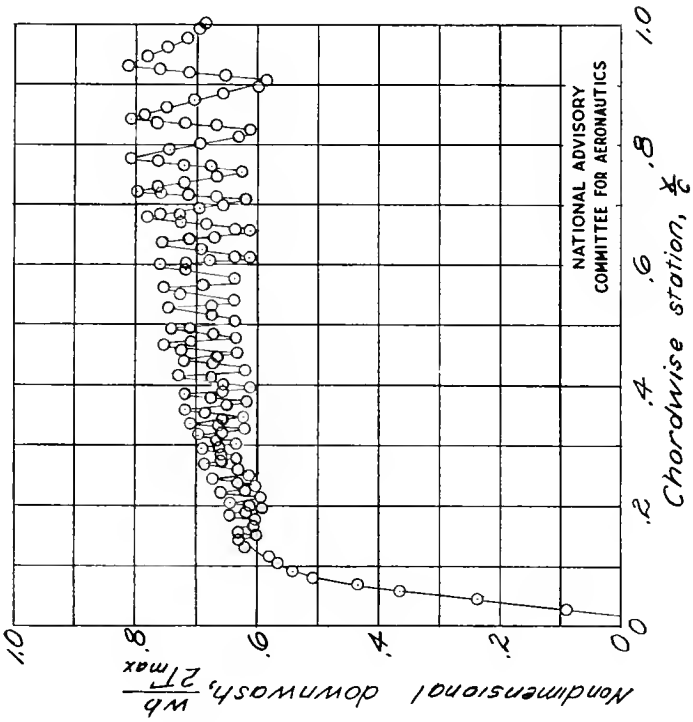

Figure 5. - Chordwise distribution of the nondimensional downwash $\frac{wb}{2\Gamma_{max}}$ at $\frac{y}{b/2} = 0$ and $\frac{z}{b/2} = 0.011$. Flat-plate type of loading.

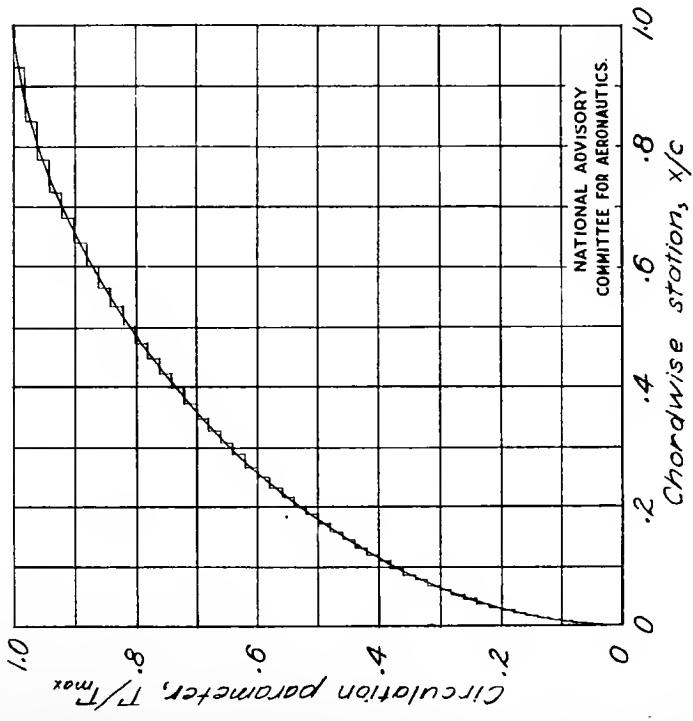
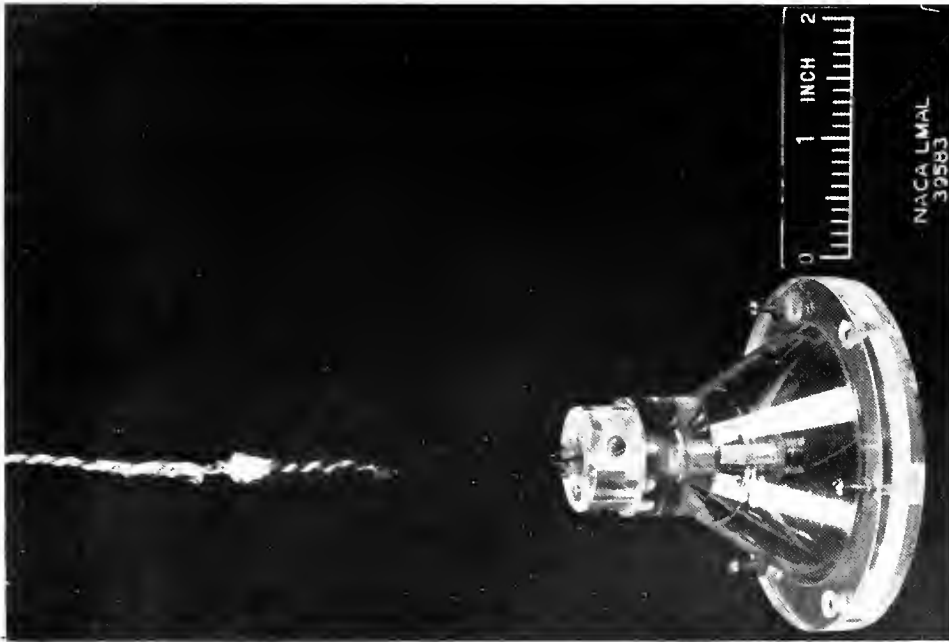

Figure 4. - Continuous and stepwise distribution of the circulation parameter Γ/Γ_{max} at the plane of symmetry; 50 steps.



Figure 6.- An electromagnetic-analogy model constructed of flat aluminum strips. (Model represents one semispan of an elliptic wing having an aspect ratio of 3 with elliptic chord loading.)



(b)

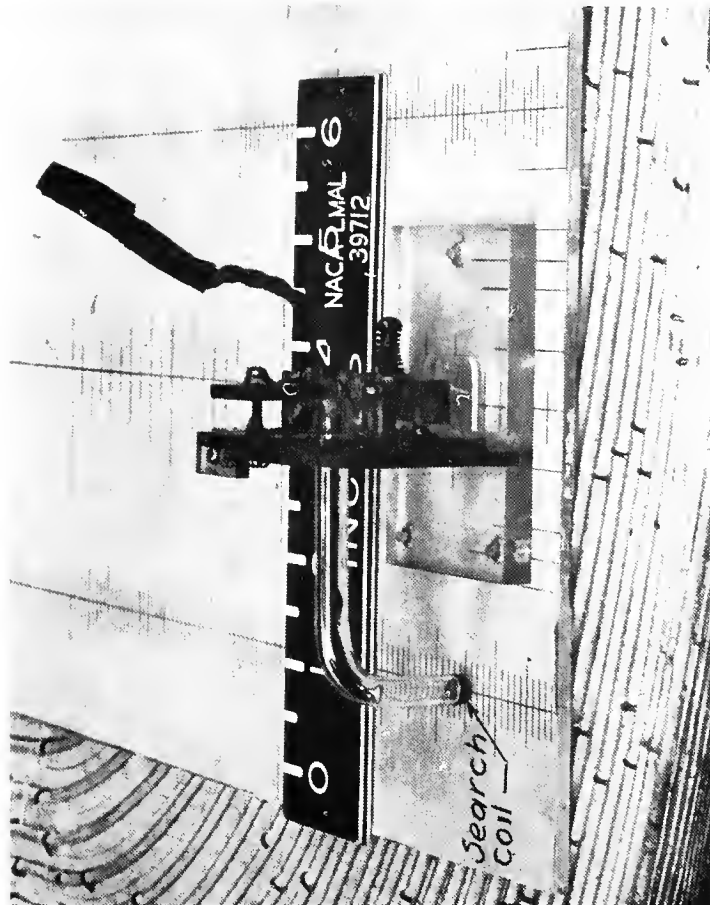

(a)

Figure 7.- Representative search coils.

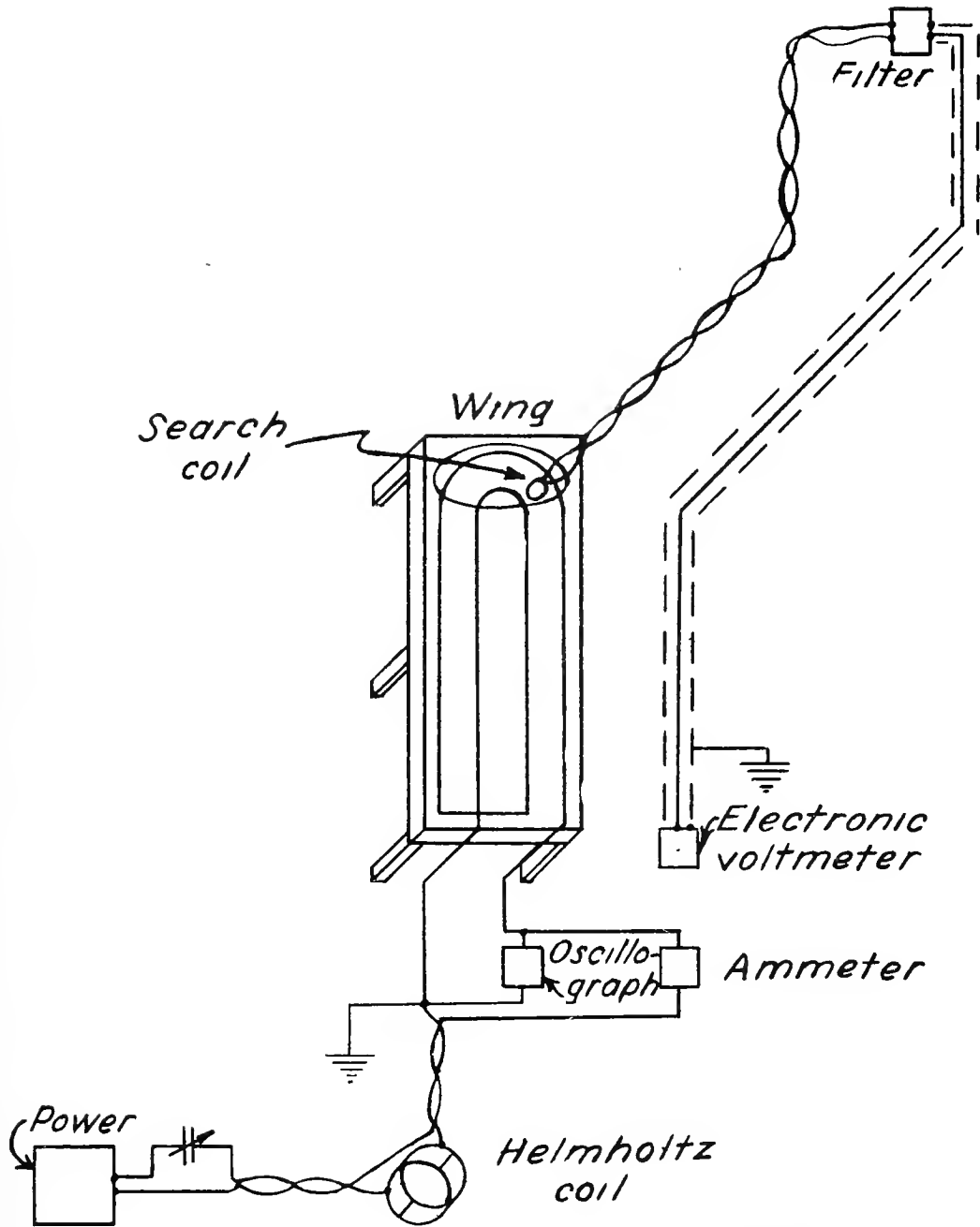

NATIONAL ADVISORY
COMMITTEE FOR AERONAUTICS

Figure 8.-General arrangement of electromagnetic-analogy experiment.

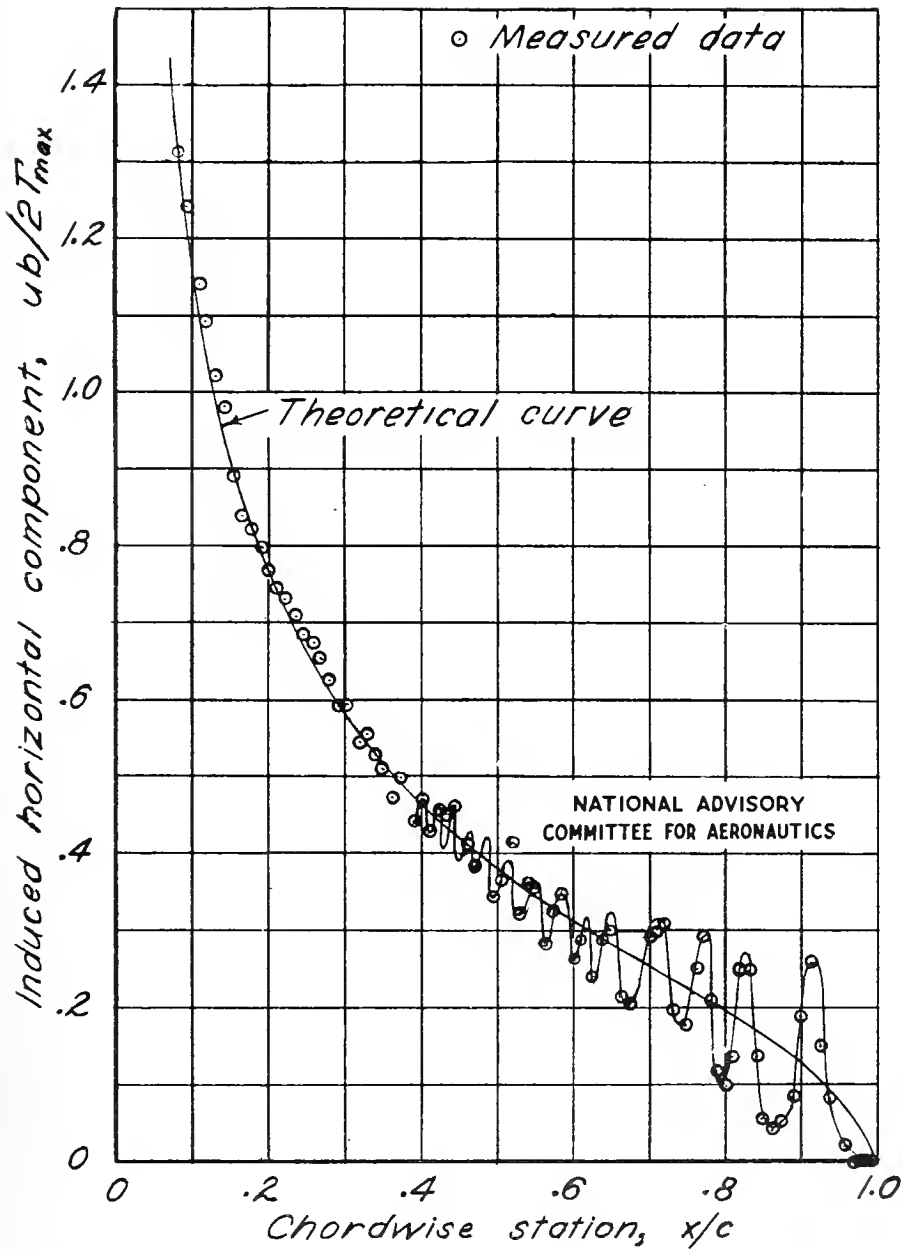

Figure 9. - Chordwise distribution of the nondimensional horizontal velocity component $u_b/2\Gamma_{max}$ at $\frac{y}{b/2} = 0$ and $\frac{z}{b/2} = 0.008$. Flat-plate type of loading.

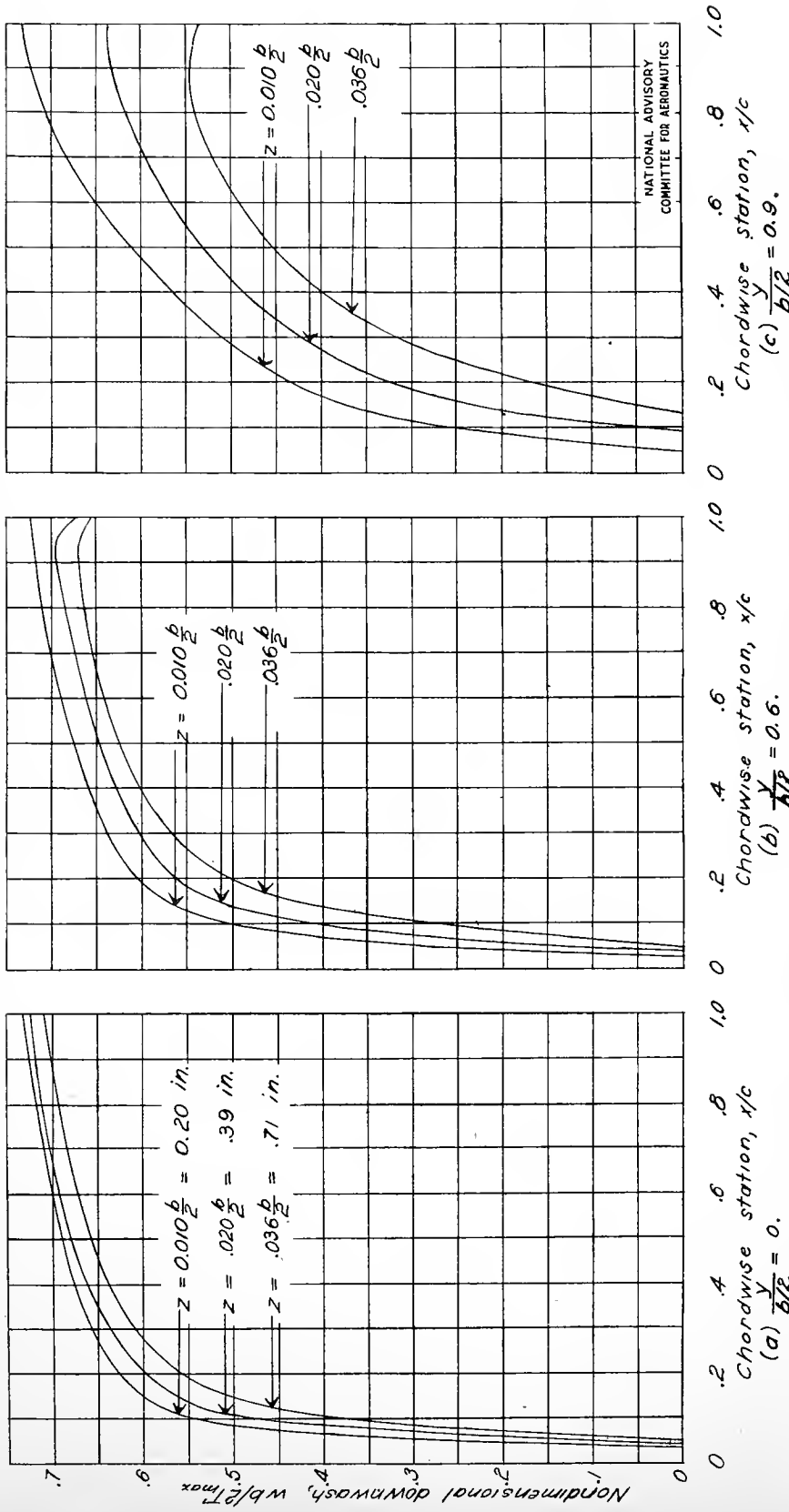

Figure 10.- Induced downwash for several vertical heights at several spanwise stations for an elliptic wing having an aspect ratio of 3 with flat-plate type of loading. Faired curves from measured data.

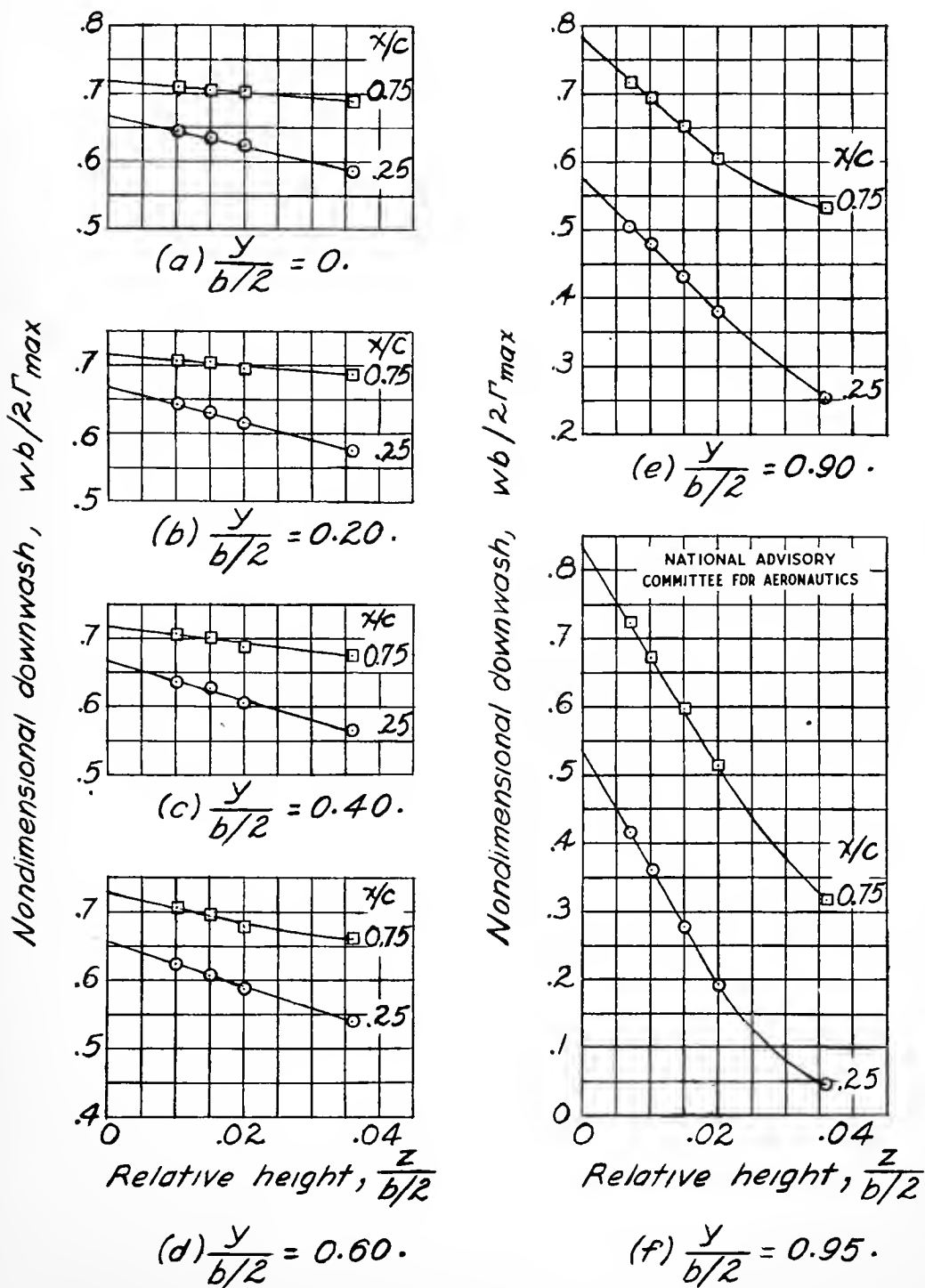

Figure 11.- Extrapolation to zero vertical height of data obtained from an electromagnetic-analogy model of an elliptic wing having an aspect ratio of 3. Flat-plate type of loading.

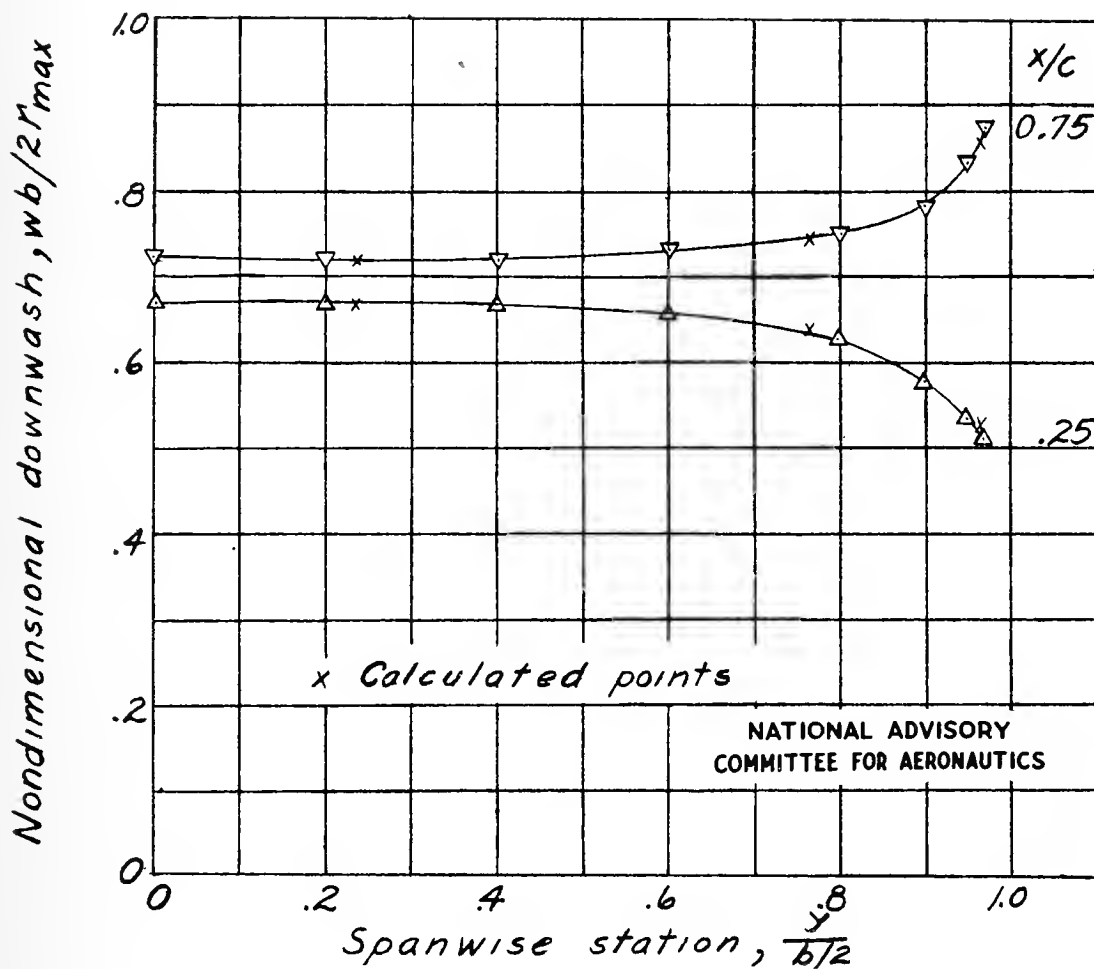

Figure 12.-The nondimensional downwash $\frac{wb}{2\Gamma_{max}}$ for an elliptic wing having an aspect ratio of 3 with flat-plate type of loading. Comparison of results obtained by method of reference 2 with data, extrapolated to $z = 0$, obtained from tests of preliminary electromagnetic-analogy model.

UNIVERSITY OF FLORIDA



3 1262 08104 968 5

UNIVERSITY OF FLORIDA
DOCUMENTS DEPARTMENT
120 MARSTON SCIENCE LIBRARY
P.O. BOX 117011
GAINESVILLE, FL 32611-7011 USA